

# Assembly and installation instructions

## LORO-X Filling and ventilating pipes, DN 40 - DN 50

**General technical approval no. Z-38.4-194**

### 1. Assembling the LORO-X slip-in socket joint

In accordance with AbZ-38.4-194 point II 2.1, the LORO-X filling and ventilation pipes and their parts must comply with the special stipulations and appendices of the national technical approval (AbZ). The national technical approval (AbZ) can be downloaded at [loro-x.com](http://loro-x.com). Store LORO-X sealing elements at room temperature for easier assembly in case of lower outside temperatures.

1.1 Apply original LORO-X adhesive, no. 985X to the sealing chamber with a brush. Place sealing element in inclined position on the edge of the sealing chamber. Push in top sealing element with your finger and let it engage in the sealing chamber until the collar of the sealing element lies level on the socket edge.

1.2 Apply **original LORO-X adhesive, no. 985X** with a brush over the entire surface on the inside of the sealing element and the outside of the insert pipe.

1.3 Line up the socket and insert pipe and push together. Twist gently to secure. Push the insert pipe in as far as the socket base.

1.4 Finished LORO-X socket joint for **LORO-X ventilation pipe**

1.5 The **original LORO-X anchor clip no. 806X** is additionally prescribed for all socket joints of LORO-X filling pipes and for **LORO-X ventilation pipes installed underground**. Bolts for DN40: Use 15mm hex wrench, tighten with 30Nm, Bolts for DN50: Use 15mm hex wrench, tighten with 30Nm. Anchor clips may only be used once and must be replaced after loosening the screws.  
**Note:**  
Only bends with a large radius may be used in the filling pipe.

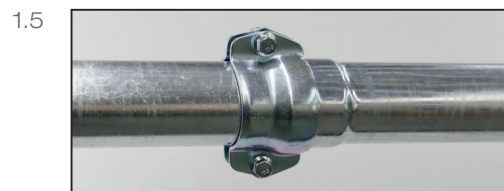
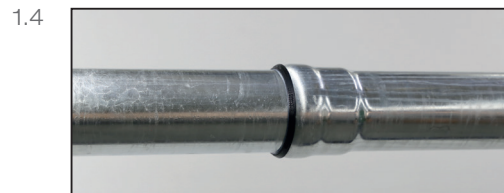
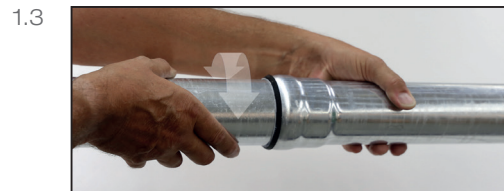

### 2. Cutting to length

It is best to use a pipe cutter to cut the LORO-X pipes to length. When cutting, the zinc coating provides cathodic protection for the inner pipe and prevents under-rusting. They can also be cut at right angles to the pipe axis with an angle grinder with a parting wheel or saw. After chamfering, a post-treatment with cold zinc is recommended as additional corrosion protection.

**The pipe ends must be deburred inside and outside.**

If a pipe section has no socket, add a LORO-X double socket no. 560X, to turn it into a socket pipe. The double socket must be glued onto the remaining pipe with the LORO-X sealing element, no. 911X, and LORO-X adhesive, no. 985X.

Filling pipes and ventilation pipes installed underground are to be secured against axial thrust at the connection points at both ends of the pushed-on socket with anchor clips, no. 806X.

### 3. Pipe fastening

We offer the following pipe fasteners in our product range:  
- Pipe clips with knocking pin  
- Pipe clips with connecting thread for hanger bolt or set screw  
The LORO-X pipe clips are mounted on straight pipes at distances of  $\leq 2.0$  m when fastening filling or ventilation pipes to walls or ceilings.

**4. Leak-tightness values of the filling pipe**

The required leak-tightness values for the filling pipe of maximally 10 bar are achieved with the anchor clip.

**5. Releasing the socket joint**

Heat the insert pipe well with a soft soldering flame close to the socket rim until the pipe can be pulled out of the socket. The tip of the flame should be about 10 cm away from the pipe to be heated. The sealing element is to be renewed when reassembling the socket joint.

**6. Underground installation**

LORO-X ventilating pipes: If ventilation pipes of heating oil tanks are installed underground, the customer must provide them with corrosion protection according to DIN 30672:2000-12. If installed underground, the socket joints of the ventilation pipes must also be equipped with LORO-X anchor clips, no. 806X.

LORO-X filling pipes: Underground installation is permissible only in a liquid-tight protection pipe or liquid-tight duct if the requirements of TRbF 50 (technical regulations for inflammable liquids), June 2002, no. 3.3 are met.

Hazard class of the liquid to be stored	Filling pipe		Ventilation pipe	
	above ground	underground	above ground	underground
A III (heating oil)	permissible with anchor clip	permissible with anchor clip	permissible without anchor clip	permissible with anchor clip

The tank manufacturer's instructions must be observed.

**7. Connection to tank systems**

The connection of LORO-X pipes to various tank systems can take place:

- a) directly, with sealing element and original anchor clip (in the filling pipe), if the top filling and ventilation systems of battery tank systems consist of original LORO-X pipes or have already been provided by the tank manufacturer with an adaptor piece with LORO-X socket.
- b) with LORO-X connectors with internal and external thread - depending on the type of tank.

**8. Approval and area of application**

LORO-X filling and ventilation pipes made of hot-dip galvanized steel are approved under the national technical approval no. Z-38.4-194 from the German Institute for Building Technology.

The subject of this national technical approval is the use of filling and ventilation pipes for pressureless heating oil tanks for the storage of heating oil according to DIN 51603-1.

The filling pipes are manufactured exclusively in the nominal diameter DN 50.

In accordance with TRbF 20 (technical regulations for inflammable liquids), issued May 2001, no. 9.1.2.3, the ventilation pipes can be manufactured in both nominal diameters DN 40 and DN 50.

The filling pipes may be operated with an operating pressure of maximally 10 bar at heating oil temperatures of up to 40 °C.

The leak-tightness values of the LORO-X push-fit socket connections are at least 0.5 bar.

In filling pipes and in ventilation pipes installed underground, the socket joints are to be additionally

secured against axial thrust with the LORO-X anchor clip. The required leak-tightness values for the filling pipe of maximally 10 bar are achieved with the anchor clip.

Local regulations also need to be adhered to if used in a region that is at risk of earthquakes. Due to the national technical approval, LORO-X filling and ventilation pipes do not require the suitability determination or the type approval according to Art. 63 of the Federal Water Act (of 31 July 2009).

Labelling of the filling system:

The permissible operating pressure must be permanently and clearly labelled on the completed LORO-X filling pipe in accordance with section 1 (4). Corresponding stickers are included in the scope of delivery of the filling connector.

**9. Other fitting instructions**

9.1 Pipes with corrosion protection (hot-dip galvanising) can afterwards no longer be welded.

9.2 The weight of continuative pipes must not exert a load on the tank system and must be supported for example, by the masonry. Furthermore, care must be taken that any small settlements are compensated by offsets (see illustration) in the continuative pipe.

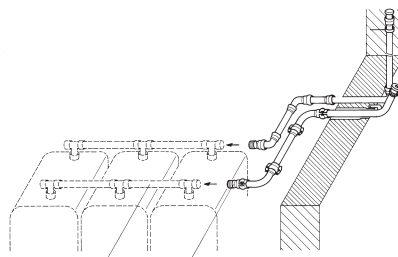

9.3 To protect against mechanical damage, protection pipes no. 716X or no. 718X are recommended for the exterior wall duct.

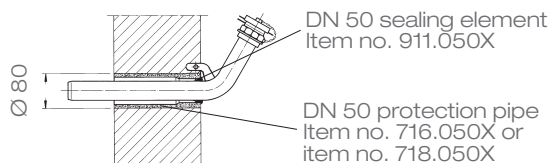

The fastening anchor is to be permanently bricked into the wall on account of the twist protection.

**10. Painting**

Hot-dip galvanized steel discharge pipes can be painted. Use paints specially designed for hot-dip galvanized substrates.

**11. Local conditions and regulations must be observed.**



#### Installation examples

LORO-X filling and ventilating pipe  
for **underground heating oil containers**  
(underground tank)

##### Material

###### Filling pipe:

F 1 = LORO-X filling pipe for underground tanks, with  
DN 50 immersion pipe

F 2 = Filling pipe fastener

###### Ventilation pipe: DN 40 or DN 50

E 1 = LORO-X connector with external thread

E 2 = LORO-X pipe, intermediate length depending on  
system

E 3 = LORO-X angle bend with external thread 1 1/2"  
or 2"

E 4 = detachable pipe fitting, flat-sealing, both ends with  
internal thread (commercially available)

E 5 = LORO-X connector with external thread

E 6 = LORO-X pipe, intermediate length depending on  
system

E 7 = LORO-X anchor clip (underground installation,  
provided with additional outside corrosion protection  
by customer)

E 8 = LORO-X angle bend for wall duct (underground  
installation, provided with additional outside corrosion  
protection by customer)

E 9 = LORO-X ventilation pipe (provided with additional out  
side corrosion protection by customer if installed  
underground)

E 10 = LORO-X safety vapour cover

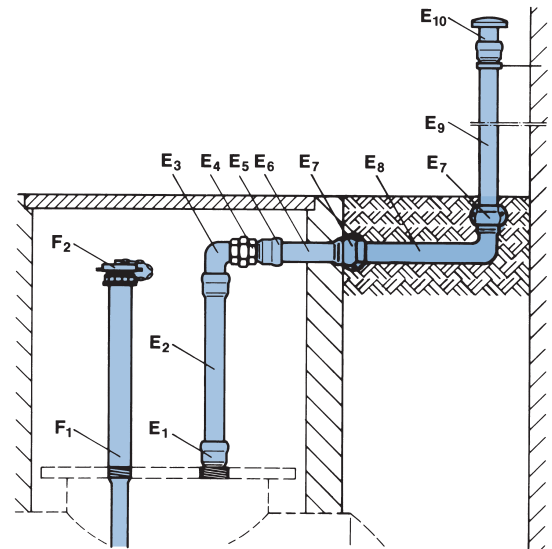

LORO-X filling and ventilating pipe  
for **heating oil battery tanks**

##### Material

###### Filling pipe:

F = Top filling pipe belonging to the tank system,  
ending at the last tank with 2" external thread or  
with LORO-X socket for direct connection,  
additionally with anchor clip

F 1 = LORO-X connector with 2" external thread or  
internal thread and DN 50 socket, omitted in case  
of direct connection option

F 2 = continuative pipe with LORO-X filling pipe fittings  
and pipes

###### Ventilation pipe: DN 40 or DN 50

E = Ventilation pipe belonging to the tank system,  
ending at the last tank with 2" or 1 1/2" external  
thread or 2" internal thread or for direct  
connection

E 1 = LORO-X connector with 2" external thread or 2"  
internal thread or 1 1/2" internal thread and  
DN 40 or DN 50 socket, omitted in case of direct  
connection option

E 2 = continuative pipe with LORO-X ventilation pipe  
fittings and pipes

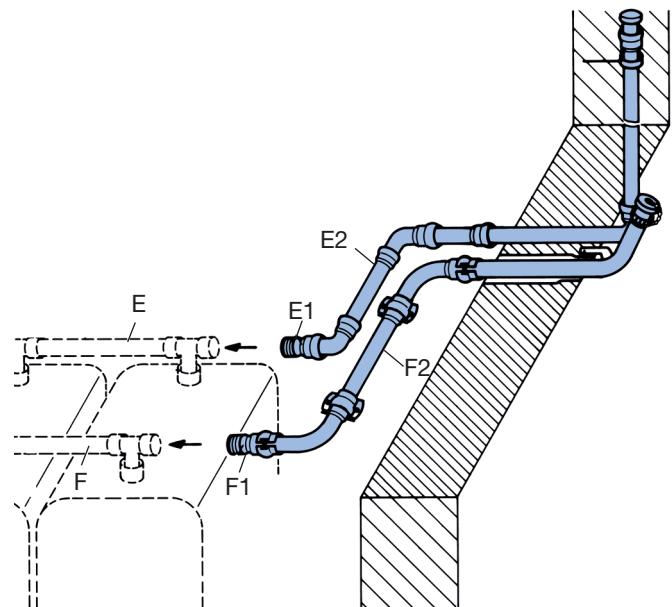

## Installation instructions for wall installation box

**LORO stainless steel wall installation box** for heating oil filling pipe, to fit LORO-X DN 50 pipe suitable for wall thicknesses 240 mm - 360 mm

**Art.-No. 00741.050X**

### Special features:

- Housing made entirely of rustproof stainless steel
- Filling connector does not protrude from the masonry
- Appealing optical design
- Delivered complete with:
  1. Filling connector DN 50-2" with fastening flange, 2" brass filling pipe fastener, cable conduit for customer's limit signalling device and fastening material, all as loose accessories
  2. Drill hole for acceptance of the limit signalling device connecting plug (DIN 6620/6625 sheet 1)
  3. Lockable, removable door with circumferential rubber seal, including square socket key

The LORO-X anchor clip is prescribed for every LORO-X socket joint in the filling pipe.

### **Observe the LOROWERK installation instructions and DIN 4755!**

Apply only original LORO-X adhesive to the upper step of the socket and the LORO-X sealing element before inserting the pipe into the LORO-X socket.

### **Do not use lubricants or similar!**

The LORO wall installation box is suitable for battery tanks made of steel, aluminium or plastic. In every case it offers a clean and purposeful solution with many extras in and on the box.

Particularly when it comes to the installation of oil tank pipes in accordance with the approval, it is especially important to pay attention to the labelling, that is required by the DIN standard, and the related system security. In order to be sure that you did not receive a mixed delivery unintentionally, pay attention to the original "LORO" labelling on the products delivered to your construction site.

